

Knife Holders

Knife Holders

Paper Labels Tape Film/Foil Nonwoven Aluminium Non-Ferrous Metals Steel OEM

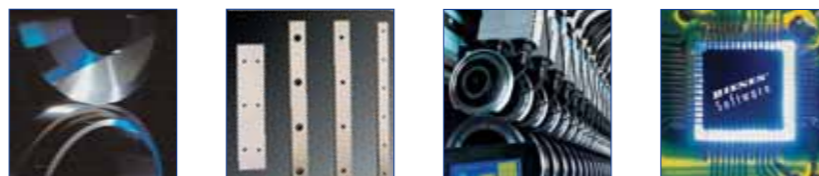

Paper Labels Tape Film/Foil Nonwoven Aluminium Non-Ferrous Metals Steel OEM



Dienes Werke Germany

Kölnener Straße 7
Postfach 1320
D-51484 Overath
Phone: +49 (0) 2206 605-0
Fax: +49 (0) 2206 605-111
E-Mail: sales@dienes.de
Internet: www.slitting-world.com
www.dienes.de

[Dienes Germany](#) [Dienes USA](#) [Dienes Hungary](#) [Dienes Poland](#) [Dienes Asia](#)



World Class Slitting – Worldwide

[Dienes Germany](#) [Dienes USA](#) [Dienes Hungary](#) [Dienes Poland](#) [Dienes Asia](#)



**Dienes – It may be possible to copy us, but we are always a step ahead.
More than one million sold knife holders speak for themselves ...**

High performance machines operating at high speed or slitting difficult materials demand innovative, specific solutions.

In many cases it is not possible to meet all customer requirements and their special application demands with standard knife holders.

The customers' demand for an optimized return of investment can only be met with slitting stations and positioning systems that are tailor-made for the respective requirements. Our colleagues at the Dienes slitting laboratory are constantly working on optimum and customer-specific solutions to increase the longevity, sturdiness, high functionality and user convenience of our systems.

Many patents of the Dienes Group trace back to these intensive research activities.

Research allowed Dienes Werke to set a new slitting speed record. With the recently developed PSG 150 Speed, high performance shear cut knife holder, it was possible for the first time, worldwide, to reach slitting speeds of up to 3,500 m/min (11,484 FPM).

All these developments help to considerably increase knife service life even under extreme conditions, and at the same time to reduce dust formation and setup times by perfectly harmonized systems that maintain the highest of safety standards.

This brochure gives you an overview of the Dienes knife holder assortment. The indicated models represent the variety of individual configurations that were developed in accordance to customer specifications and cooperation.

In addition to the Dienes knife holders that have been adjusted to the respective applications and materials, more than 200 different designs – as initial equipment or retrofit system – have led to notably more profitable machine performance. Thus, even the profitability of older winding machines increased dramatically by upgrading them with modern slitting systems.

For this customer-oriented operation, Dienes products have obtained their reputation as leaders in terms of slitting quality.

Innovations that offer our customers a clear edge over their competitors:

Patented Dienes know-how.

- High speed holder 3,500 m/min (11,484 FPM)
- Driven shear cut holder
- Constant side load CSL
- Double axle guidance DF
- Quick-change head WKS
- Adjusting slide Easy Set
- 360° knife guard
- Shear angle plate
- Micro depth adjustment
- Quik-Clamp™ QC
- Replacement tools
- Vibration analysis
- Electronical service life control
- Spring-energy memory FES
- Telematic service and much more ...

Dienes | The Cutting Edge.

1. Shear Cut Knife Holders

We can offer you the following holder designs with pre-loaded, zero clearance, double axle guiding – individually engineered to the specific slitting task.

Elite:

- PSGm 19 DF
- PSGm 25 DF
- PSGs DF 50
- PSGs DF Power
- PSG DF 145
- PSG DF 150 Speed
- PSG DF 150 Motion
- PSG DF 145 Control

Competitor comparable single axle holders are also available.

Premium:

- PSGm 16
- PSGs 50
- PSG 1

2. Crush Cut Knife Holders

Various double axle guided options are available based on the material to be cut, slit width and web speed.

Top Quality:

- PQA DF 19
- PQA DF 50

As well as with single axle guidance:

Quality:

- PQG
- PQAS 6,35 - 12,7 mm
- PQDS 6 - 20 mm
- PQA MC/PQD MC
Slit Width 20 mm

3. Slitting Cassettes

For a quick and safe slit width adjustment choose our:

Series Easy Box :

- Crush Cut Module III
Slit Width from 4 mm
- Dienes Mini Cut
- Shear Cut Cassette

4. Heat Cut Holders

The following basic models for extensible materials are available:

- Heated Crush Cut
PQAS BH
- Crush Cut Heat Cut
PQAS H

5. Razor Blade Cut Holder

When it comes to razor blade cutting, Dienes leads in terms of quality and user-friendliness.

- Pneumatic Knife Holders with Razor Blade Heads
- Crush Cut Knife Holders with Razor Blade Arms
PQAS R, PQDS R
- Individual Razor Blade Holders
- Razor Blade Cassettes

6. Safety Accessories and Service Tools

Our safety accessories and service tools make an important contribution to the safety of Dienes quality knives:

- Hand Guards
- Blade Exchange Tools
- Protective Hand Gloves
- Adjusting Aids
- Maintenance Tools
- and more ...

Dienes | Always a cut ahead.

Applications	Elite Shear Cut Knife Holders				Premium Shear Cut Knife Holders			Crush Cut Knife Holders			
	PSGm 19 DF	PSGm 25 DF	PSGs DF 50	PSG DF 145	PSGm 16	PSGs 50	PSG 7	PQA DF 50	PQG	PQAS, PQDS	PQA MC, PQD MC
Material to be Cut*											
Aluminium < 500 µm	+	+	+	+	+	•	•	-	-	-	-
Aluminium > 500 µm	-	-	+	+	-	•	•	-	-	-	-
Double-layered Aluminium	-	-	+	+	-	-	-	-	-	-	-
Cable Bands < 300 µm	+	+	+	+	•	•	•	-	-	-	-
Lithography Bands > 500 µm	-	-	+	+	-	•	•	-	-	-	-
Synthetic Foils < 500 µm	+	+	+	+	•	•	+	-	-	-	-
PVC, PE, PP 500 – 1500 µm	-	-	+	+	-	-	-	-	-	-	+
Paper < 200 g/m ²	+	+	+	+	+	+	+	-	-	•	•
Paper 200 – 500 g/m ²	+	+	+	+	-	+	+	-	-	-	-
Paper 500 – 800 g/m ²	-	-	+	+	-	-	•	-	-	-	+
Paper > 800 g/m ²	-	-	-	+	-	-	-	-	-	-	-
Adhesive Tapes/Labels	-	•	+	•	-	•	•	+	+	+	+
Beverage Packaging	-	-	+	+	-	•	•	-	-	-	-
Textiles	•	•	•	•	•	•	•	+	+	+	+
Rubber / vulcanized, unvulcanized	□	□	□	□	□	□	□	□	□	□	□
Nonwoven / Tissue, Hygiene Fleece, Glass Fleece	□	□	□	□	□	□	□	□	□	□	□

Legend: + suitable • conditionally suitable - unsuitable □ Knife holder selection has to be determined through slitting tests at Dienes slitting laboratory.

*Just an example of different materials. Consult us regarding your specific material challenges.

PSGm 19 DF

PSGm 25 DF

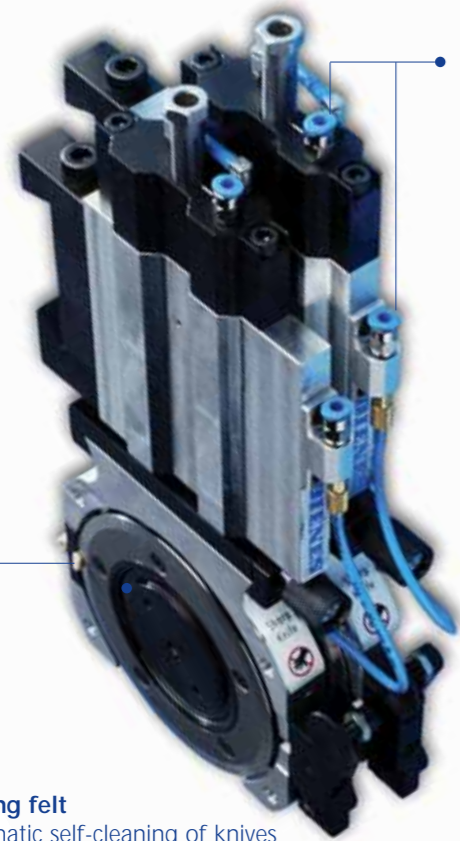

Individual vertical loading
• adjustable side load

Quick-change head
• removal from front without slit width adjustment

Cleaning felt
• automatic self-cleaning of knives
• clean cuts

Knife Head Variants

Rigid: for hard materials as aluminium, etc.
Spring-loaded: for soft synthetics, latex, rubber, foils, etc.

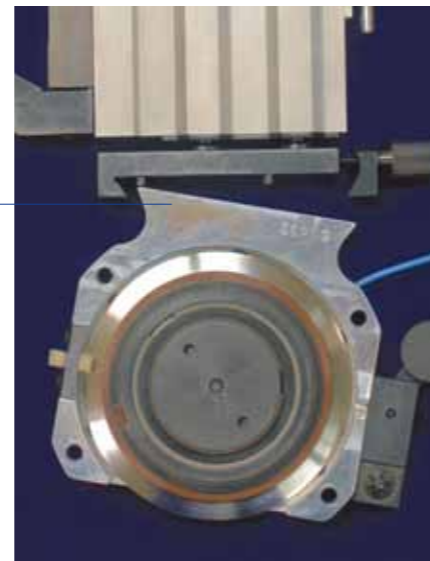

PSGm 19 DF

Our All-rounder!

The special construction of this knife holder allows zero clearance vertical and horizontal guidance. Thus, slit widths from 19 mm can be reached without sacrifices to blade rigidity.

Advantages:

- Nesting concept
- Rigid construction
- Narrow slit widths

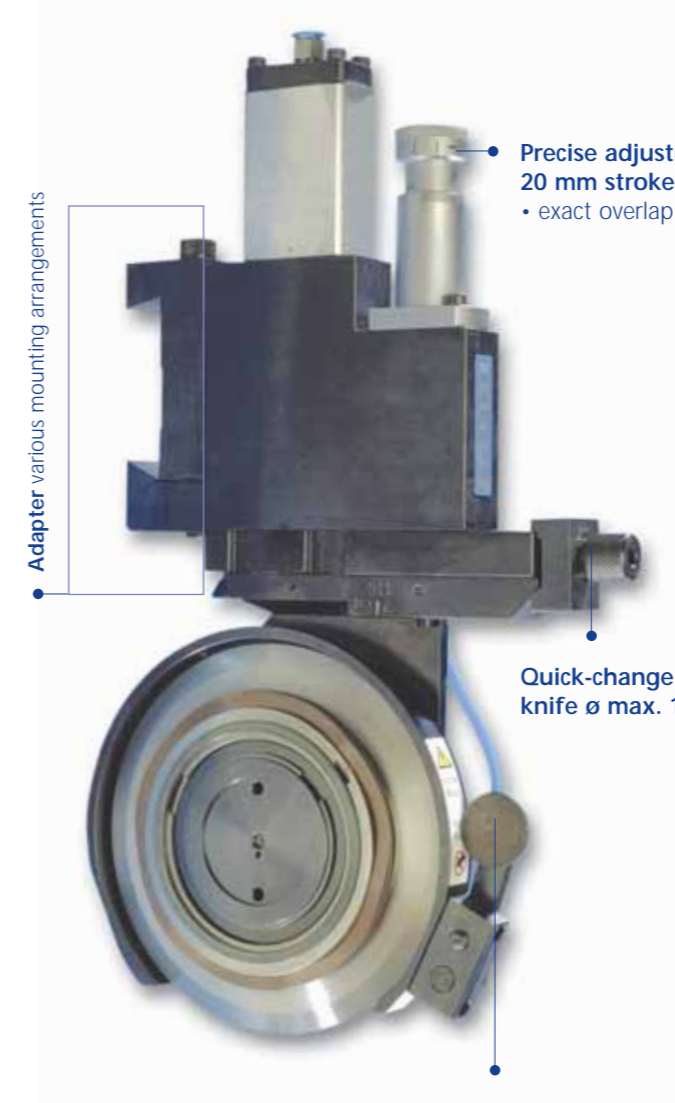
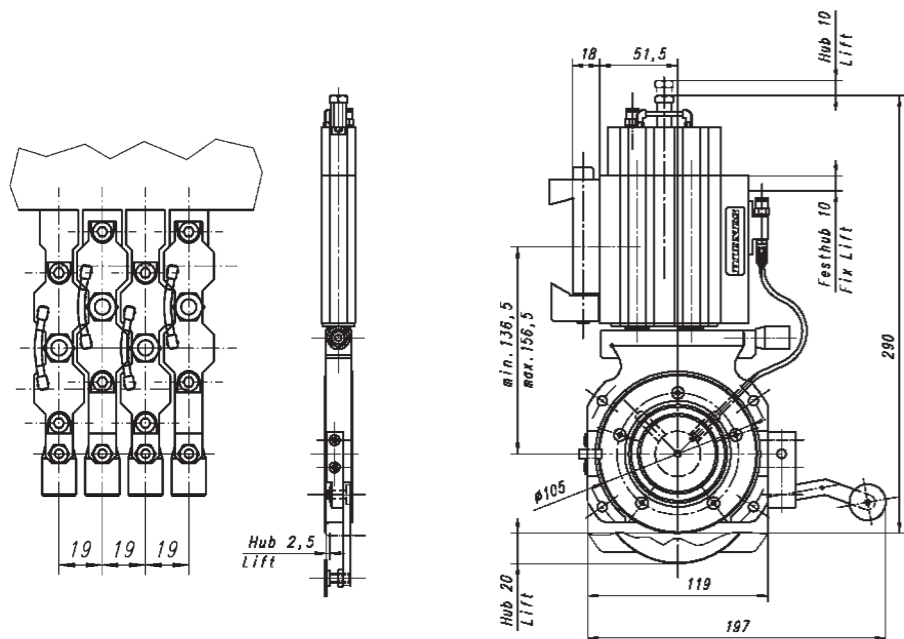

Precise adjustment of knife depth
20 mm stroke
• exact overlap depth control

Quick-change head
knife \varnothing max. 130 mm

Adjusting slide
• easy adjustment to bottom knife



PSGm 25 DF

Our Approved!

Due to its zero clearance vertical double axle guidance, this knife holder guarantees the utmost rigidity while keeping a minimum slit width of 25 mm.

User convenience is greatly increased by its precise depth adjustment and quick-change knife head for easy knife replacement

Advantages:

- Optimum slitting edge quality, even with difficult materials
- Drastic reduction of machine down times due to the quick-change head system

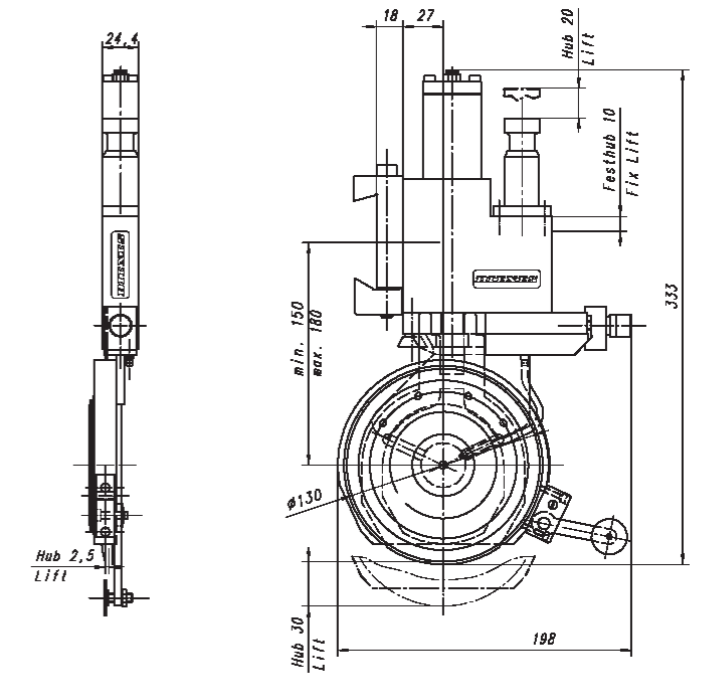

PSG DF 145

PSG DF 150 Speed



PSG DF 145

Our Strongest!

This shear cut knife holder is applicable with roll slitters as well as sheeters. It is applied to guarantee the highest slitting edge quality even under difficult application conditions.

For all its robust outside design, a great variety of developments in slitting technology have merged in this holder construction.

Advantages:

- Vibration damped guidance systems
- Zero clearance vertical and horizontal guiding of the knife head movement
- Suitable for slitting single- and multi-layer paper
- Solves difficult material slitting tasks



PSG DF 150 Speed

Our Fastest!

The first shear cut knife holder that has been successfully used in practice for cutting speeds up to 3,500 m/min (11,484 FPM).

This knife holder is known for its patented vertical knife head guidance, completed by a precise knife overlap depth adjustment and the sensitive "constant side load" system (CSL).

Advantages:

- Dramatically increased knife service life
- Reduced dust generation
- Reproducible, low knife contact pressures

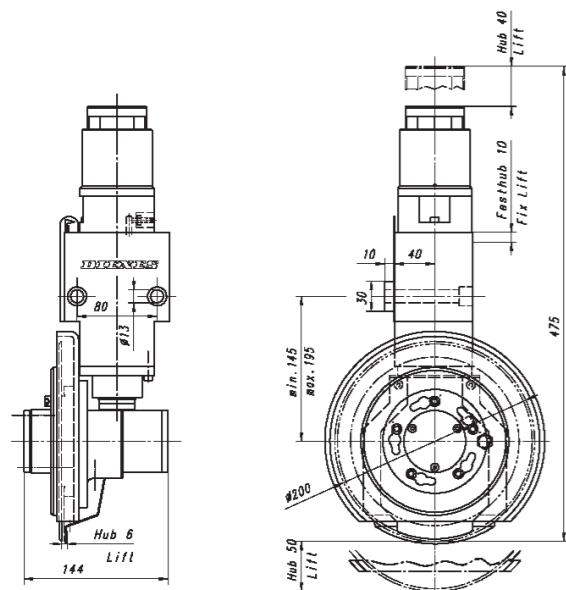

Linear bearing mounted for increased user convenience and dramatically reduced setup times (see accessories)!

Constant Side Load System (CSL)

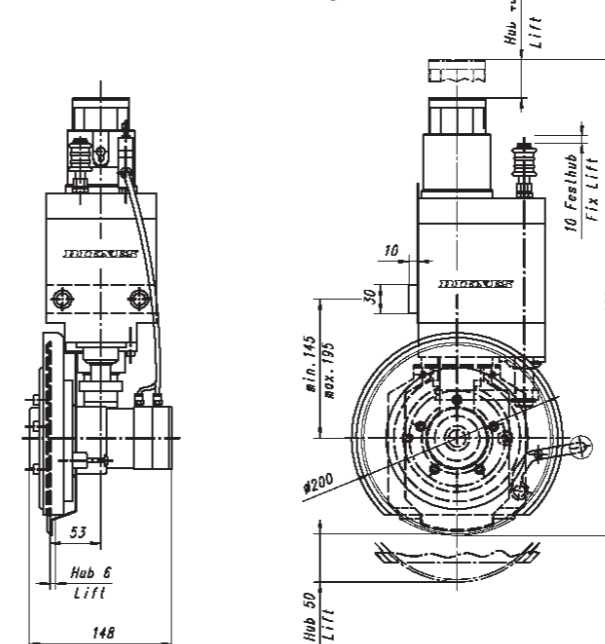

Technical Data / Application Recommendation

- Weight: 24 kg
- Min. slit width: 150 mm
- Cutting speed: 3,500 m/min. (11,484 FPM)
- Axial operating pressure: 1-6 bar

other data as PSG DF 145

Premium

Shear Cut Knife Holders Premium

PSGm 16

Premium

PSGs 50/PSG 1

Various mounting arrangements
• compatible with all machine designs

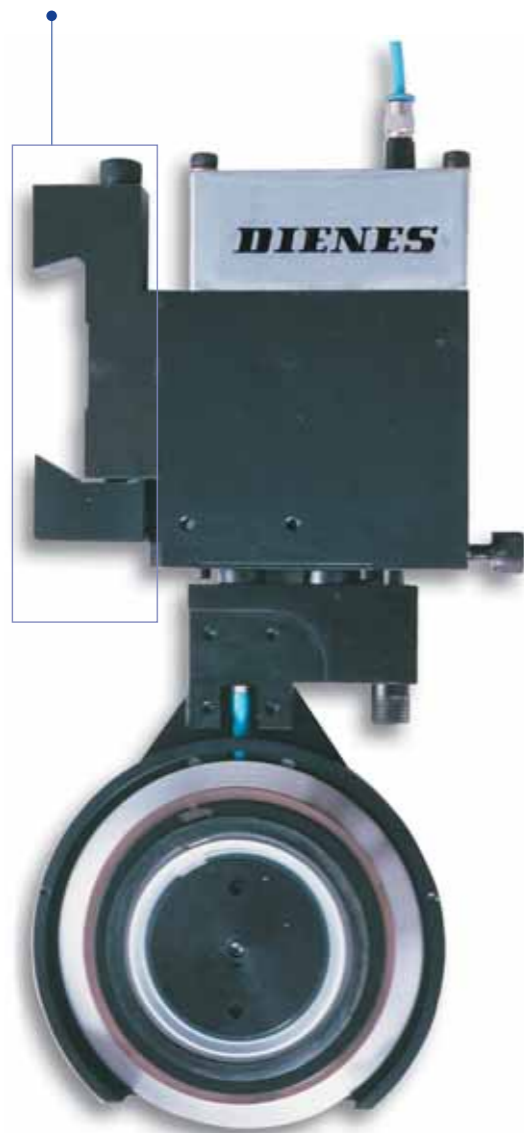

PSGm 16

Our Smallest!

Our narrowest knife holder with approved zero clearance vertical double axle guidance for slitting narrow bands from 16 mm.

Advantages:

- Due to the small holder width, it is not necessary to use collars or bars with staggered knife holders.
- Noticeably increased profitability due to quick slit width adjustment

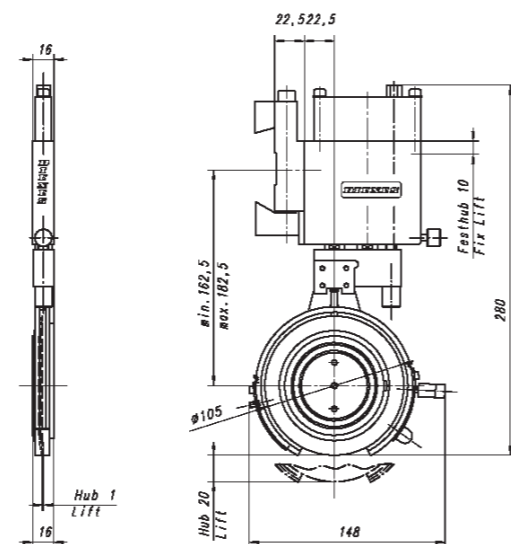

Increased user convenience and dramatically reduced setup times due to the linear guidance (see accessories)!



PSGs 50

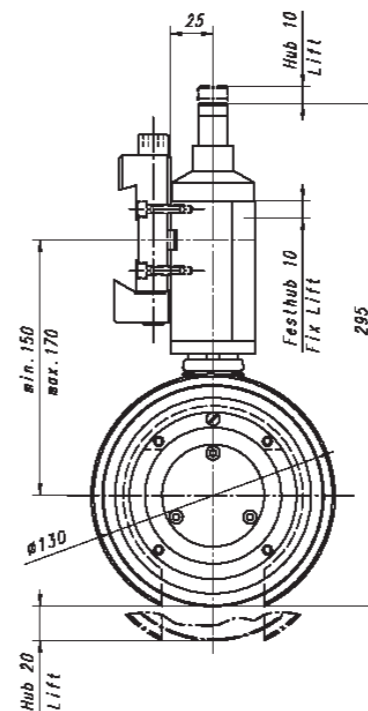

PSGs 50 and PSG 1

Our Classics!

The construction of these two shear cut knife holder designs has been proven for many years and their functionality even for extremely difficult applications has been demonstrated. Its easy handling and adjustment as well as its almost maintenance-free operation are distinctive.

PSG 1 DK

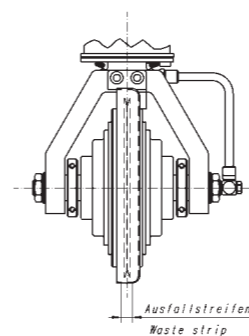

Double knife head for separating waste strips from 5 mm



PSG 1

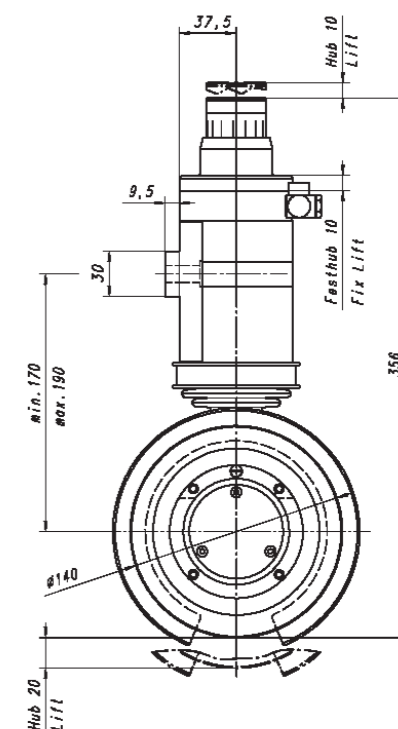



PQA DF 19

Dienes' New Development!

The special construction of this knife holder design allows a zero clearance vertical guidance. Therefore it is possible to reach slit widths from 19 mm without sacrificing holder stability.

Advantages:

- Optimum slit edge quality, even with difficult material to be cut
- Drastic reduction of machine-down times due to quick-change head system

PQA DF 50

Our Precise One!

This crush cut knife holder design meets the demand for a narrow overall width while offering the utmost stability even with high slitting speeds.

Its outstanding feature is the zero clearance, vibration-damped vertical guidance of the knife head.

Advantages:

- Maximum vertical force due to optimized piston surface
- Increased knife service life
- Optimum slitting edge quality, even with difficult material to be cut
- Well approved for grooving and cracking labels, adhesive tapes, label-stock, etc.
- Depth setting in steps of 0.02 mm

Micro depth adjustment

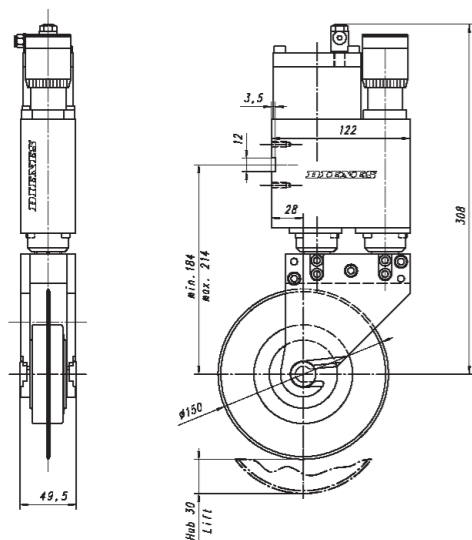

• Exchange head with quick-clamping device

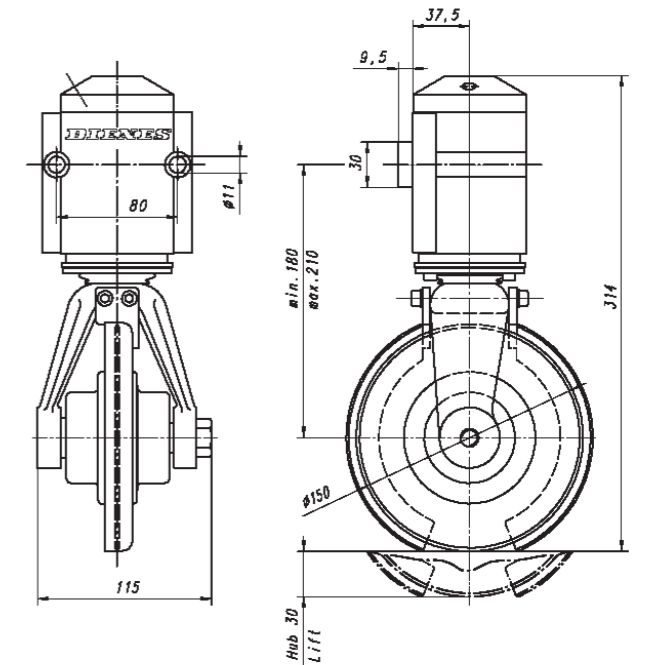

PQG

Our Solid One!

This crush cut knife holder offers proven technology at an attractive price. It has been used for many years in the most varied applications, e.g. rubber production and rubber processing, fleece materials, and many more.

Advantages:

- High product quality
- Applicable for high slitting speeds and difficult manufacturing conditions
- Toolless quick-change head available as an option

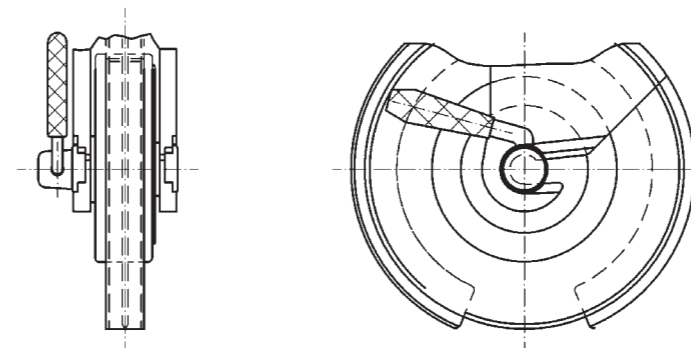

PQAS/PQDS

QUIK-CLAMP™

Our Universals! Worldwide successfully in use for slit widths of 6-20 mm for many years.

Advantages: • High product quality • Easy handling • User convenience

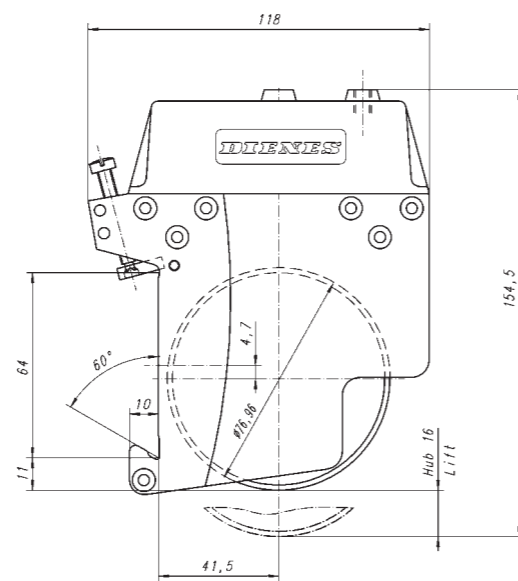

PQAS available with the following holder widths:
6.35/9/9.525/10/12/12.7 mm

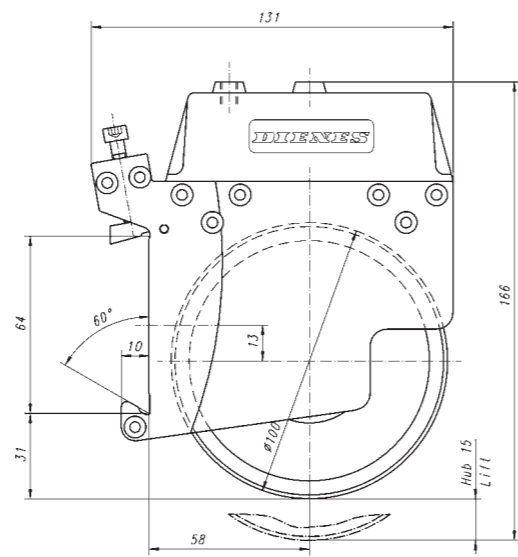

PQDS available with the following holder widths:
6/9/9.525/10/12/12.5/15/20 mm

All Crush Cut Knife Holders available with hand protection

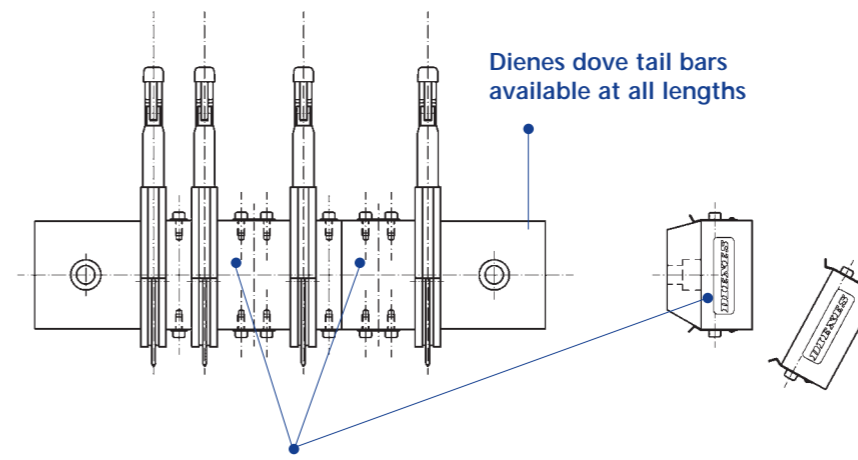

Dienes precision spacers for exact slit width adjustment available at all thicknesses



PQD MC3 PQAS
Option (with 2- and 3-fold cylinders) for higher slitting force capability



QUIK-CLAMP™

Dienes QUIK-CLAMP™ system is well approved for applications with frequent slit width adjustments. It is available as an option for the Dienes standard crush cut knife holders of type PQDS and PQAS.

The QUIK-CLAMP™ system eliminates set screw set-up variances.

Advantages:

- Rectangular clamping of the holders
- Minimum setup times
- Toolless repositioning of the crush cut knife holders
- For module application

Dienes Mini Cut:

- Optimised exactness due to pre-adjusted slitting widths
- Optimised equal and easy running of the knives
- Ease of operation even with smallest slitting widths (4 mm)

PQAS BH/PQAS H

The Heated Cut PQAS BH

By heating the knives, it is possible to prevent adhesive sticking to the knife edge which could lead to customer-rejected finished rolls.

Preferred Application:

Adhesive materials

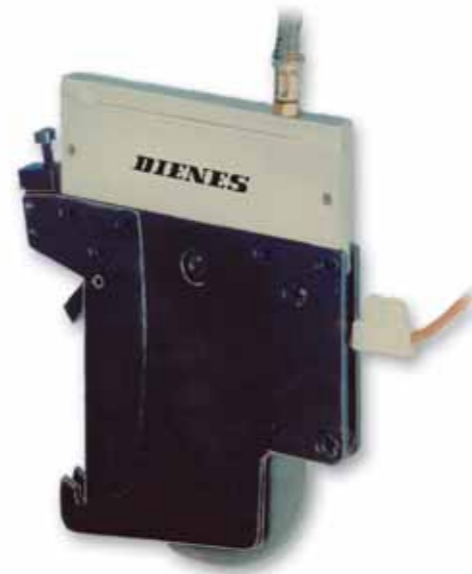

Dimensions see PQAS/9.525 mm holder width.

Heat Cut PQAS H

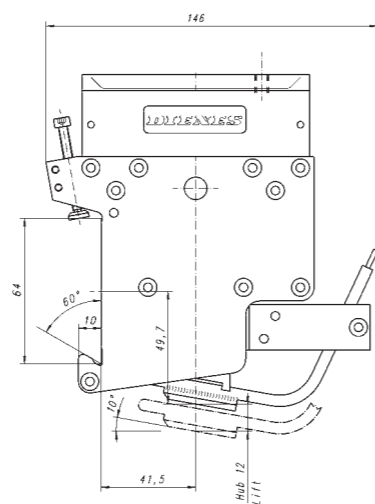
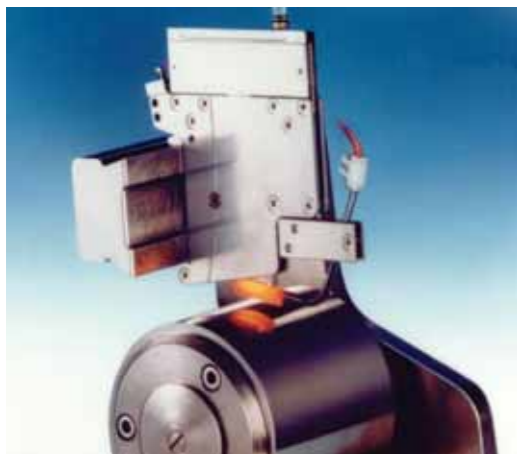

9.525 mm holder width

Due to the high temperature, the material is separated and simultaneously the slitting edges are welded.

Preferred Application:

Technical textiles
Polyethylene webs

An electronic thermo control is also available at Dienes.
Infinitely variable temperature adjustment relative to material thickness and web speed.

Razor Blade Cut

Shear cut knife heads can be exchanged for razor blade heads within seconds and thus they are applicable to the most varied material thicknesses. This applies to the following holders: PSGm 25 DF, PSGs 50, PSGs DF 50

Preferred Application:

Slitting of very thin synthetic and metal foils is more profitable with razor blades.



Razor blade head with adjustable engagement angle, which lengthens blade life.

Razor Blade Holders

Slit widths from 3 mm have already been realized successfully.

For very narrow slit widths, our razor blade holders are also available in cassette design.

Our approved crush cut knife holders PQAS/PQDS are available with razor blade adapter as an option.

Razor Blade Materials

- Tungsten carbide
- Solid ceramic
- Ceramic coated
(Diamond Black Blade)



PQDS R

Diamond Black Blade

Diamond Black Blade

The Dienes blade with highest service life and superior sharpness.

Individual solutions for razor blade cut on request!

Accessories

Accessories and Service Tools

Adapter variants, e.g. Holder PSGs DF 50

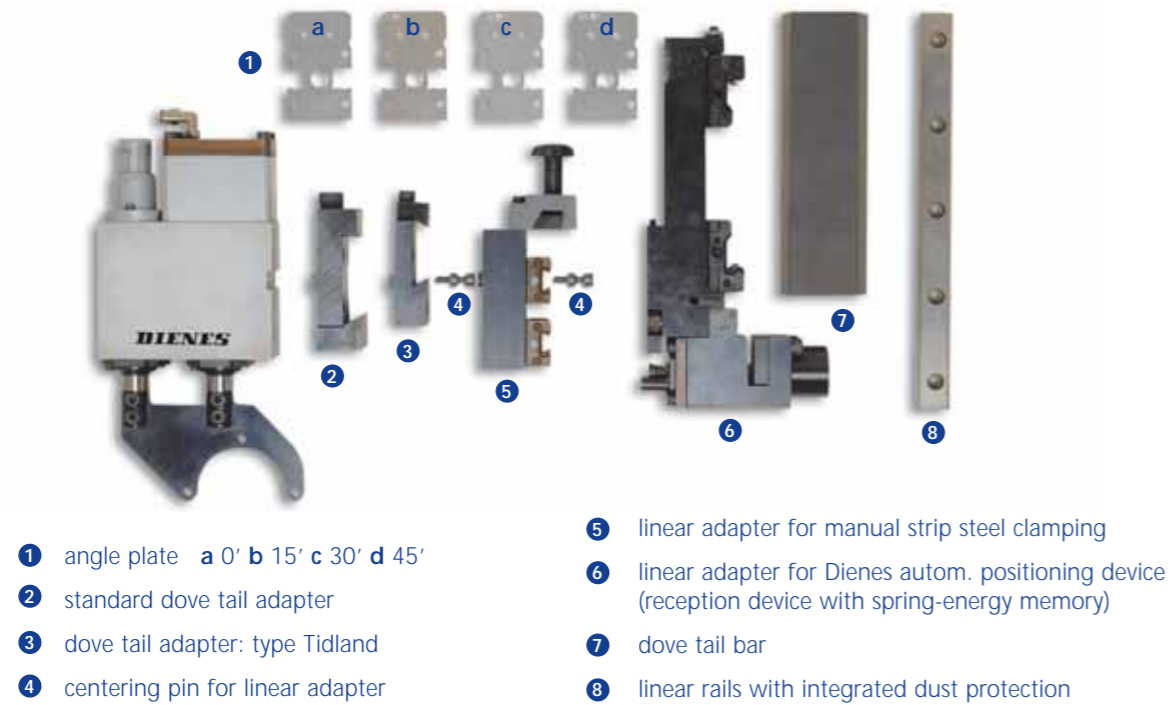

- 1 angle plate a 0° b 15° c 30° d 45°
- 2 standard dove tail adapter
- 3 dove tail adapter: type Tidland
- 4 centering pin for linear adapter

- 5 linear adapter for manual strip steel clamping
- 6 linear adapter for Dienes autom. positioning device (reception device with spring-energy memory)
- 7 dove tail bar
- 8 linear rails with integrated dust protection

Increased user convenience for all holders and dramatically reduced set-up times due to linear rail guidance!

Knife head variants, e.g. Holder PSGs DF 50

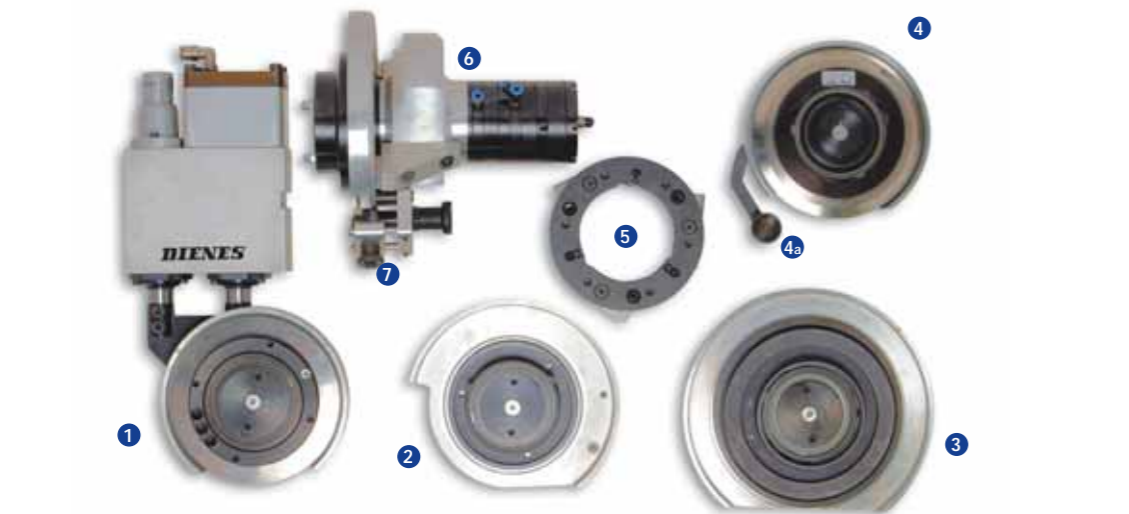

- 1 standard knife head ø 130 mm rigid (spring-loaded knife)
- 2 quick change knife head ø 150 mm, special hand protection
- 3 quick change knife head ø 180 mm
- 4 quick change knife head spring-loaded knife ø 130 mm

- 4a adjusting slide Easy Set
- 5 razor blade head
- 6 knife head CSL (constant side load)
- 7 felt wiper with axial stroke

Pneumatic Control System

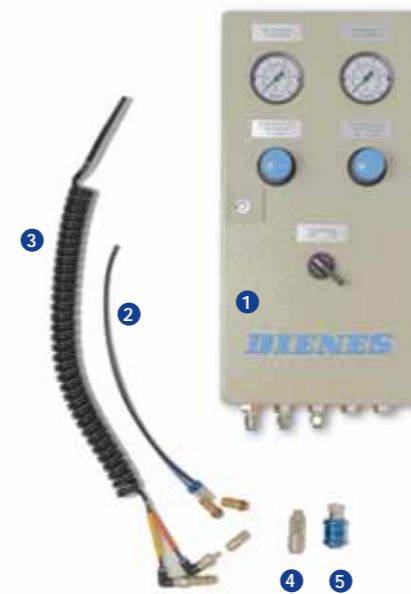

- 1 Dienes pneumatic control for the compressed air supply
- 2 DUO hose with plug coupling
- 3 DUO spiral hose with plug coupling
- 4 Stainless steel fittings
- 5 Dienes hand slide valve



Various tools for a professional assembly/disassembly are available.

Assembly Tools



e.g. various tongs, fork and hook spanners

Service Aids



e.g. manuals, gloves, dust-exhaust, and more ...

Tech. Data

Technical Data/Standard Holders

	Elite Shear Cut Knife Holder				Premium Shear Cut Knife Holder			Crush Cut Knife Holder			
	PSGm 19 DF	PSGm 25 DF	PSGs DF 50	PSG DF 145	PSGm 16	PSGs 50	PSG 1	PQA DF 50	PQG	PQAS/PQDS	PQD MC 3
Dimensions/Weight											
total height*1	300 mm	335 mm	330 mm	475 mm	280 mm	305 mm	372 mm	383 mm	315 mm	150 mm	140 mm
total width*2	19 mm	25 mm	50 mm	144 mm	16 mm	48.5 mm	113 mm	49.5 mm	115 mm	6-20 mm	20 mm
total weight*3	2.4 kg	3.7 kg	6.1 kg	16 kg	2.1 kg	4.6 kg	8.9 kg	8.4 kg	8,1 kg	0.7/2 kg	2 kg
Working Data											
min. slit width	19 mm	25 mm	50 mm	145 mm	16 mm	50 mm	115 mm	50 mm	100 mm	from 6 mm	20 mm
vertical knife stroke	20 mm	30 mm	30 mm	50 mm	20 mm	20 mm	20 mm	30 mm	30 mm	15 mm	15 mm
non-adjustable stroke	10 mm	10 mm	10 mm	10 mm	10 mm	10 mm	10 mm	10 mm			
adjustable stroke	10 mm	20 mm	20 mm	40 mm	10 mm	10 mm	10 mm	20 mm	30 mm		
horizontal knife stroke	2.5 mm	2.5 mm	2.5 mm	6 mm	1 mm	1.5/3 mm	3 mm				
knife diameter	max. 105 mm	max. 130 mm	130/150/180 mm	max. 220 mm	max. 105 mm	max. 130 mm	140/180 mm	max. 150 mm	max. 150 mm	76.96 /100 mm	76.96 /100 mm
Application Range	1,200 m/min	1,200 m/min	2,000 m/min	2,600 m/min	800 m/min	1,200 m/min	1,300 m/min	1,100 m/min	800 m/min	300/400 m/min	300/400 m/min
operating pressure vertical	3/6 bar	4.5/6 bar	4-6 bar	4/6 bar	5/6 bar	4-10 bar	4/10 bar	max. 8 bar	max. 10 bar	max. 6 bar	max. 6 bar
operating pressure axial	3/6 bar	4.5/6 bar	max. 3.5 bar	4/6 bar	5/6 bar	max. 6 bar	max. 6 bar				
max. slitting force at 6 bar								1200 N	900 N	240 N/540 N	1620 N
shear angle	from 0° to 1° in steps of 15'							0°			
cutting angle								30°/45°/60°			
knife head construction	right-hand or left-hand										
holder mounting	optionally dove tail guidance, linear guidance, T-groove bar or to customer specification										

You will find an example of the extensive Dienes accessories and service tools on page 22/23.

*1 total height without air connection

*2 width may vary depending on the options

*3 weight may vary depending on the options

Subject to technical alterations!

Service

Dienes B2B Knife Management System, Kaizen Analysis and Regrinding Service

Dienes 48-h Manufacturer's Regrinding Service



Even the best knives must eventually be replaced. Dienes has made this operation faster and safer by its well-designed replacement system, with optimal protection from injuries.

The 48-hour regrinding service which operates the newest generation of CNC machines is performed under the same strict quality criteria that you expect from the Dienes Group.

In addition to seminars and in-house training sessions, the regrinding service is an important component among the various services provided by Dienes.

Regrinding and polishing machines by Dienes are easy to operate. They are offered to customers that wish to regrind and polish their knives inhouse.

Knife management support is not only provided through new recording, controlling and ordering systems but also through well-designed knife storage cabinets and transportation boxes.

Kaizen analyses provide comparison data for Dienes evaluation. Tests made with special knife holders will lead to measurably improved slitting quality, handling, service life and operational safety.



48-h Manufacturer's Regrinding Service

Even the best knives have to be reground some time. Whether circular or straight knife, the Dienes Regrinding Service offers more than just grinding: cleaning, precision measuring, 2-phase CNC/NC precision grinding and optionally anti-dust surface with test report.



Dienes storage box



Dienes shipping boxes in various designs



Increase

- Productivity
- Service life
- Slitting edge quality
- Demand on quality
- Effectiveness

Reduce

- Knife operating costs
- Knife demand
- Machine down times
- Slitting dust
- Maintenance and stock-keeping

Improve

- Machine performance with the perfect comparison data of the DIENES Kaizen analysis.
- Your knife management control with DIENES products and systems.

For information please contact:

Dienes Werke Germany

Kölner Straße 7
Postfach 1320
D-51484 Overath

Phone: +49 (0) 2206 605-0
Fax: +49 (0) 2206 605-111

E-mail: sales@dienes.de

Internet: www.slitting-world.com, www.dienes.de

On request we will send you these information on CD-Rom. Visit our digital world: www.dienes.de

Directions to Dienes Werke:

Coming from Cologne going east on A4 towards Olpe:

Take exit 22. At the bottom of the exit ramp turn right onto the B55. Drive for approximately 1.5 km. Dienes will be on your left-hand side.

Coming from Olpe going west on A4 towards Cologne:

Take exit 22. At the bottom of the exit ramp turn left onto the B55. Drive for approximately 1.5 km. Dienes will be on your left-hand side.



Dienes B2B Knife Management System

- Inventory and status control
- OPTI-Tool tool calculation
- Optimized knife requirements
- Internet knife display
- Electronic key system
- Installation logistics
- Just-in-time replacement
- Paperless transactions
- Cost control
- Cost reduction

Dienes Kaizen Analysis

- Planned/actual comparisons
- Cutting force
- Knife overlap
- Surface quality
- Regrinding quality
- Web entrance/Cant angle
- Knife head torsional play/ Knife head bearing play
- Analysis of cutting edge
- Evaluation
- Trouble shooting

Dienes Regrinding Service

- Hotline (optional)
- Pick-up
- Cleaning
- Precision measurement
- Group classification
- 2-phase CNC/NC precision grinding
- (ADS) Anti-dust surface (optional)
- Inspection
- Specifications, test report (optional)
- Shipping